



# Aftermarket Solutions

Part Supply

Engineering Support

Site Services

GREENS COMBUSTION

# Aftermarket Solutions

The Aftermarket team at Greens Combustion provides a reliable, dedicated and flexible service with 100% commitment to helping our clients maintain and operate their combustion equipment to their full potential.

Our comprehensive solutions range from part supply to site services and engineering support, all designed to help you maintain your fired equipment in the most efficient and profitable manner, optimising productivity and minimising downtime.

Our respected combustion product and process expertise helps you achieve the best from burner, flare and thermal systems, and we work closely with clients so we can fully appreciate your goals, and ensure we deliver a tailored solution for optimal performance that goes far beyond a quick fix.

We are equally expert in combustion and supply chain and logistics management, meaning we can meet your requirements and deliver customer satisfaction in every element of our service.

## Why you should choose Greens Combustion

Looking for the best-optimised solution and a well-executed project at a very competitive price? Greens Combustion is the partner for you.

- ▶ Global Reach, with presence in over twenty countries.
- ▶ Named, personal contact for your enquiry and projects.
- ▶ Broad combustion expertise, from front-end engineering studies to operating plant improvements.
- ▶ Superb aftermarket and onsite services including optimising furnaces, maintenance training, health checks, turnaround advice and supply of components.
- ▶ Expert team with years of combustion, design and project experience.
- ▶ Tailored service from engineers that understand your combustion plant and processes.

“ We guarantee a first class experience with a fast, comprehensive response to all client needs, regardless of project scope. We recognise that our industry operates on a global scale and understand the importance of visiting end users to see first-hand how your equipment is operating, and the problems you may be experiencing.”

**Neil Turle**  
Manager - Aftermarket

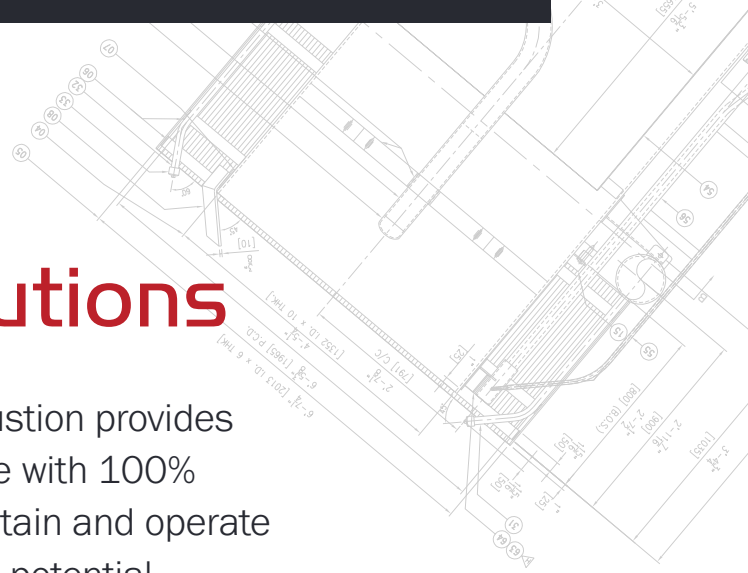

# Part Supply

The aftermarket specialists at Greens Combustion can supply a range of aftermarket parts for virtually any make and model of burner or flare.

Our expertise in combustion is matched by our experience in supply chain and logistics management, allowing us to meet the clients' requirements and deliver customer satisfaction in every element of our service.

Our parts supply service covers combustion equipment for:

- › Fired Heaters
- › Crackers
- › Boilers
- › Reformers
- › Incinerators
- › Flare Systems

**Greens Combustion part supply is facilitated through the following methods:**

## Replacement Parts & Assemblies

We've an extensive catalogue of replacement parts for our own and other manufacturers' burner and flare systems, and guarantee interchangeability between our own and other products. This removes the need for timely on-site modification when replacing non-proprietary components.

## Parts & Assemblies Supplied

- ✓ Burner Windbox & Damper Assemblies
- ✓ Flare Tips, Liquid Seals & Knock Out Drums
- ✓ Gas Nozzles, Tips & Jets + Oil Atomisers
- ✓ Complete Gas Gun, Oil Gun & Poker Assemblies
- ✓ Oil & Water Sprayer Assemblies & Parts
- ✓ Air Intake Filters & Silencers
- ✓ Combustion Air Swirlers & Stabilisers
- ✓ Burner Refractory Tiles & Modules
- ✓ Burner & Flare Pilot / Ignition Systems & Ancillaries
- ✓ Flame Detection Systems & Ancillaries
- ✓ Actuated Assemblies & Components
- ✓ Fixings, Fittings, Gaskets, Seals & Hoses

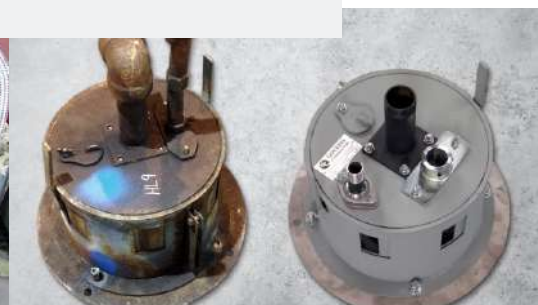

## Reverse-Engineered Parts

We can reverse-engineer existing parts and assemblies to ensure long-term supply and support when they are no longer available from the manufacturer. We can take detailed measurements of parts and assemblies during onsite visits or from returned component samples.

## Engineered Solutions

Our engineers have a wealth of practical knowledge and are adept at analysing on-site issues to identify where engineered solutions can be applied. Our solutions range from Low NOx burner conversions to meet environmental regulations to atomiser reconfigurations to reduce steam consumptions.

## Revamps

We are skilled at identifying revamp opportunities of existing installations to increase life, efficiency and capacity. A successful burner revamp can result in considerable cost savings in comparison to new supply whilst reducing maintenance, noise and emissions and increasing long term support for spare parts.

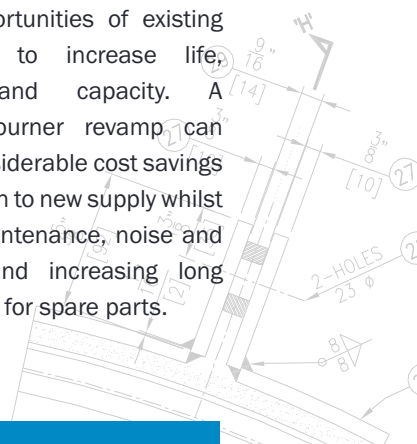



# Engineering Support

We offer comprehensive engineering support through a unique combination of combustion and burner expertise, a dedicated test facility and partnerships with industry leaders. While a simple call or email is enough to resolve many clients' operational issues, we can also offer:

## Burner Development & Testing

Our full-scale dedicated burner firing facility allows us to undertake research projects as well as optimising existing burner equipment.

Configuration	Rating and size	Preheat
Up-fired	5 MW ( $\varnothing$ 3.0m x 8.2m)	Air - 450°C / Gas - 350°C
Down-fired	3 MW ( $\varnothing$ 2.5m x 6.7m)	Air - 450°C / Gas - 350°C
Side / Up-fired	1 MW (2m x 2m x 2m)	Air - 550°C / Gas - 350°C

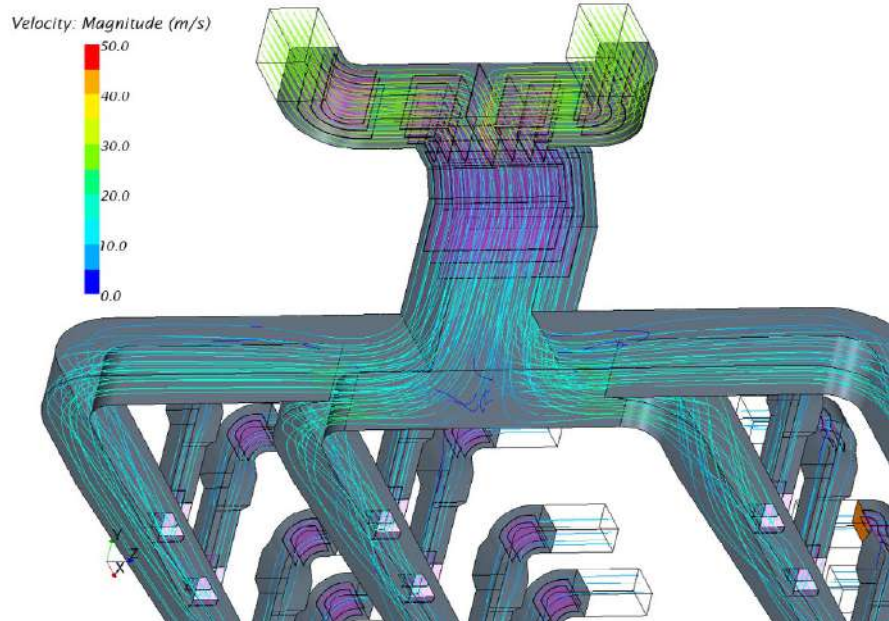
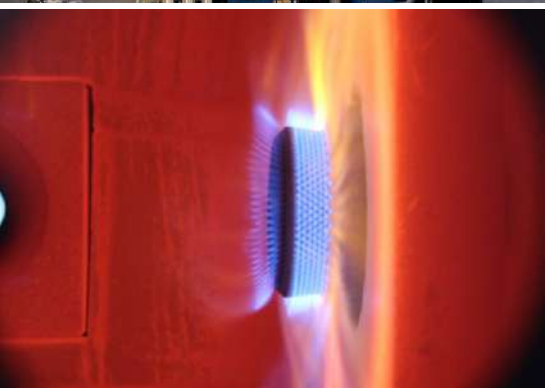



## Unmanned Aerial Vehicle (UAV) Inspections

We can complete innovative online inspections of inaccessible locations i.e. Flare stacks / Tips. We deploy a modified UAV to capture close-range visual imagery, video & thermal profiling, allowing for expert assessment of the need for maintenance or preparation for turnaround.

## Computational Fluid Dynamics

We have the technology and knowledge to execute CFD studies that accurately predict the performance of burners and furnace environments with regards to flow, turbulence, thermodynamics and combustion. We employ CFD to support burner design and validation, and to identify potential inefficiencies in existing burner, furnace and combustion air duct systems.

## Metallurgical Analysis

Metallurgical analysis, destructive and non-destructive testing of equipment can aid client assessment to provide a critical understanding of how specific characteristics of a material, or the presence of trace contaminants, has contributed to failure, or whether a material is suitable for modification.

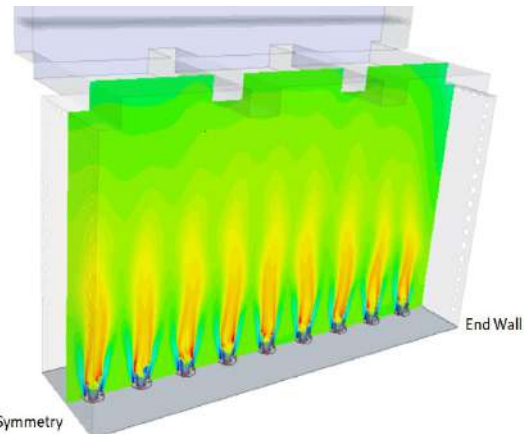
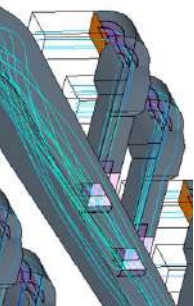

## Desktop Studies

Our desktop studies provide clients with data so they can make informed decisions about implementation and investment. Our studies can help predict whether combustion equipment will require modification for future process change, and identify opportunities for operational and efficiency improvements.

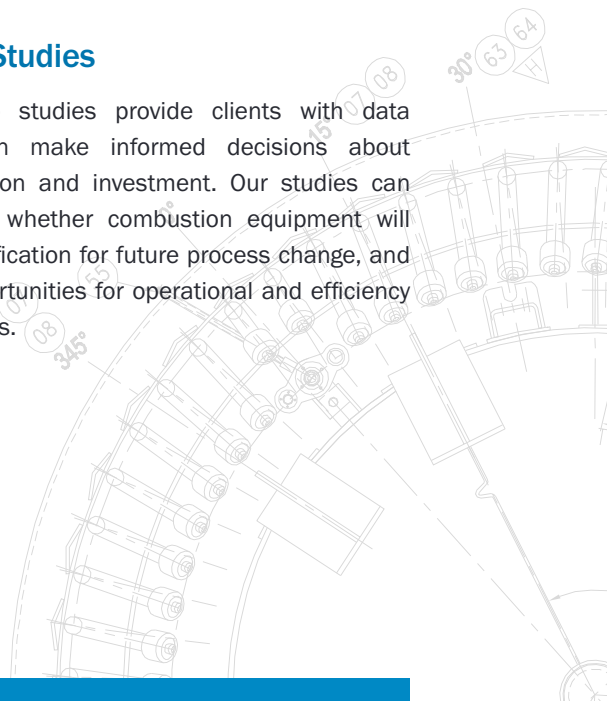



# Site Services

Our site services support our own and others manufacturers' burners, incinerators and flares, and range from onsite supervision & surveying to the delivery of bespoke training packages. Our engineers have extensive site experience and in-depth knowledge of applications, maintenance and operation.

## Our site expertise covers:

- ✓ Process Burners
- ✓ SRU Train Burners
- ✓ Boiler Burners
- ✓ Incinerator Burners
- ✓ Air Pre-Heater Burners

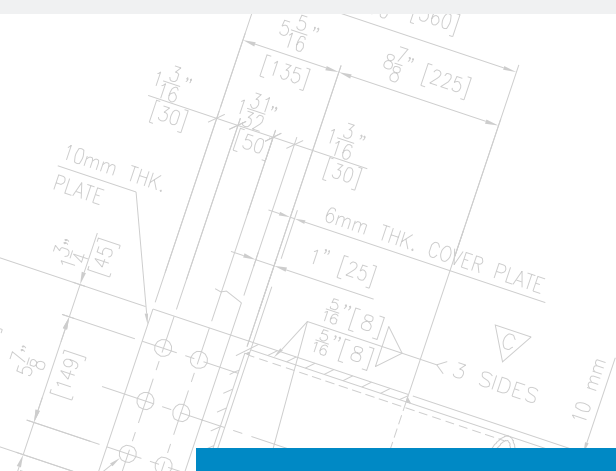

## Installation Supervision

We can supervise and manage single- or multi-heater burner installations from concept to completion. Each install team is equipped to cover process, mechanical, electrical & project activities, while our office team provides detailed installation plans. Our daily reports and timesheets provide clients with top-level oversight of our activity and progress towards installation project milestones.

## Commissioning Supervision

Our skilled site team can take a project from installation to commissioning, ably supporting dry-out, start-up, test runs and operation. Our operating manuals and performance curves ensure on-spec operation and seamless transfer of knowledge to onsite staff. We maintain our staff's certifications so they are fully qualified to deliver support, from the oil & gas safety passport to H2S awareness, confined space and offshore Bosiet & Mist certification.



## Pre-Turnaround & Combustion Surveys

Our range of surveys covers existing and new installations for our own and other burner models. Our full combustion survey can identify opportunities to optimise burner set-up and often leads to simple changes that result in cost savings through improved fuel efficiencies, longer run times and reduced downtime. Our pre-turnaround surveys can identify problems and recommend solutions for replacing components. Each helps to ensure requirements are known well in advance of a plant shutdown so provisions can be made for a seamless turnaround.

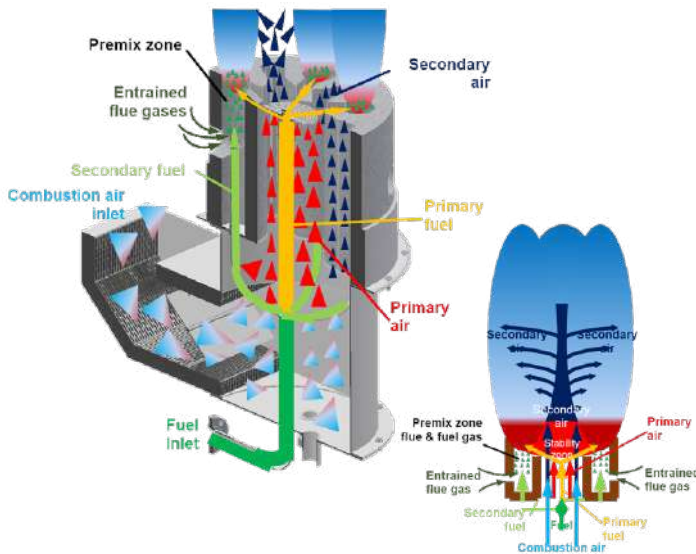

## Training

Our basic to advanced level classroom and site-based training courses are tailored to clients' requirements and typically delivered to site operators, maintainers, heater contractors and vendors. They cover burner design, operation, troubleshooting and maintenance. We also lead and participate in multi-day symposiums delivered with other industry leaders, typically providing a one-stop technical overview of heater-related technology for plant operators.

## Contact us

We'd be delighted to hear from you – speak to the friendly Greens Combustion team to learn more about how we can help deliver optimal combustion solutions, tailored to your needs.

[www.greenscombustion.com](http://www.greenscombustion.com)

+44 (0)1202 607563

**Greens Combustion Limited**

A31 Arena Business Centre  
Holyrood Close  
Poole, Dorset  
BH17 7FJ  
United Kingdom

Phone:  
+44 (0)1202 607563

E-mail:  
info@greenscombustion.com

[www.greenscombustion.com](http://www.greenscombustion.com)