

TN TYPE TN90 ... TN3000

with viscosity up to 400 cSt at 50°C (50°E at 50°C) - MECHANICAL ATOMIZATION

HEAVY OIL

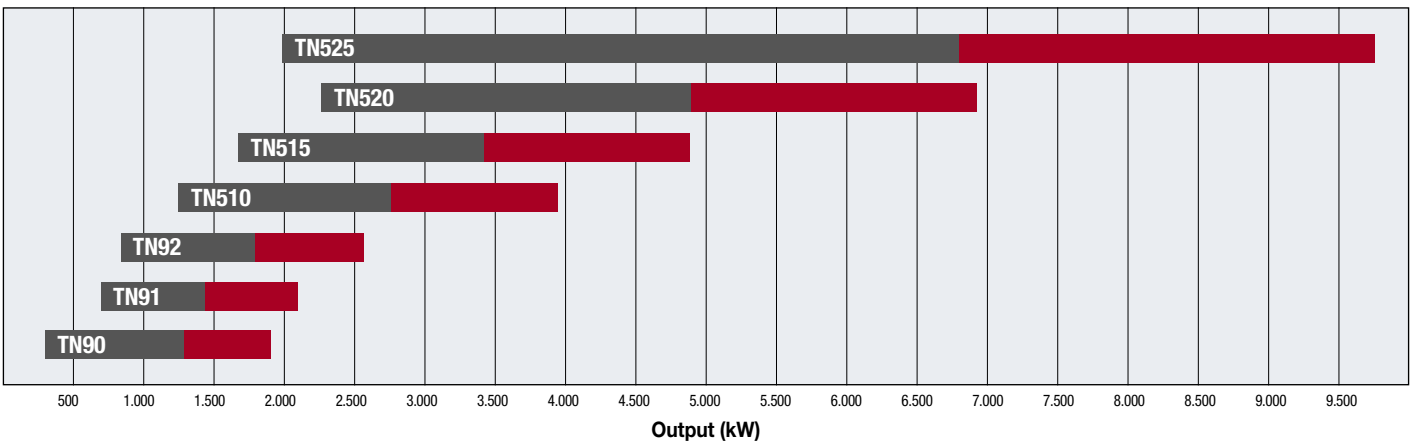
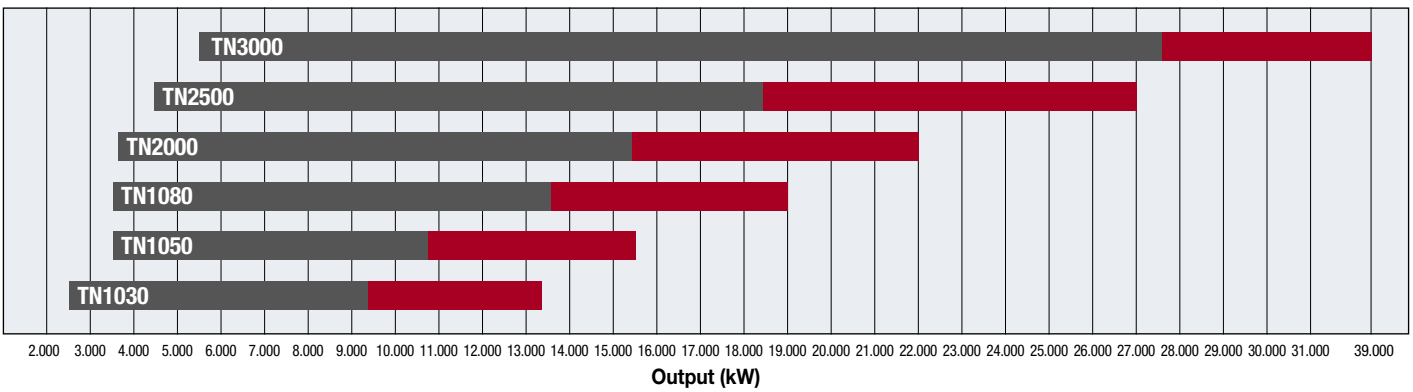
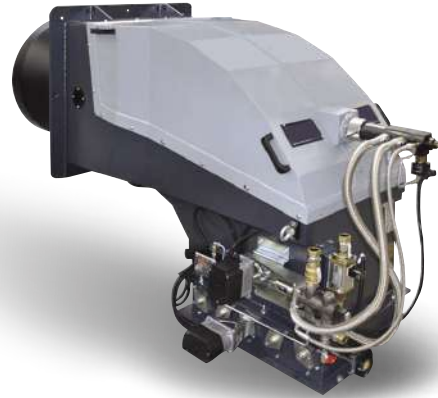

Type	Min. modulation output kW	Min. application output kW	Max output kW
TN90	264	1.330	1.900
TN91	698	1.465	2.093
TN92	849	1.791	2.558
TN510	1.314	2.767	3.953
TN515	1.628	3.419	4.884
TN520	2.326	4.884	6.977
TN525	2.000	6.825	9.750
TN1030	2.500	9.310	13.300
TN1050	3.500	10.850	15.500
TN1080	3.500	13.300	19.000
TN2000	3.600	15.400	22.000
TN2500	4.500	18.400	27.000
TN3000	5.500	27.300	39.000

TECHNICAL DETAILS

Type	Model	Power kW		Pump motor	Resistor	Auxiliary electrical power supply	Motor electrical power supply
		min.	max.	kW	kW		
TN90	D-.xx.S.xx.G.xx	264	1.900	1,1	12	230 V 1N AC 50 Hz	400 V 3 AC 50 Hz
TN91	D-.xx.S.xx.G.xx	698	2.093	1,1	18	230 V 1N AC 50 Hz	400 V 3 AC 50 Hz
TN92	D-.xx.S.xx.G.xx	849	2.558	1,1	18	230 V 1N AC 50 Hz	400 V 3 AC 50 Hz
TN510	D-.xx.S.xx.G.xx	1.314	3.953	1,1	24	230 V 1N AC 50 Hz	400 V 3 AC 50 Hz
TN515	D-.xx.S.xx.G.xx	1.628	4.884	1,5	12 + 18	230 V 1N AC 50 Hz	400 V 3 AC 50 Hz
TN520	D-.xx.S.xx.G.xx	2.326	6.977	2,2	18 + 24	230 V 1N AC 50 Hz	400 V 3 AC 50 Hz
TN525	D-.xx.S.xx.G.xx	2.000	9.750	4,0	24 + 24	230 V 1N AC 50 Hz	400 V 3 AC 50 Hz
TN1030	D-.xx.S.xx.G.xx	2.500	13.300	5,5	24 + 24	230 V 1N AC 50 Hz	400 V 3 AC 50 Hz
TN1050	D-.xx.S.xx.G.xx	3.500	15.500	5,5	24 + 24	230 V 1N AC 50 Hz	400 V 3 AC 50 Hz
TN1080	D-.xx.S.xx.G.xx	3.500	19.000	5,5	24 + 24	230 V 1N AC 50 Hz	400 V 3 AC 50 Hz
TN2000	D-.xx.S.xx.G.xx	3.600	22.000	5,5	ON REQUEST	230 V 1N AC 50 Hz	400 V 3 AC 50 Hz
TN2500	D-.xx.S.xx.G.xx	4.500	27.000	5,5/7,5	ON REQUEST	230 V 1N AC 50 Hz	400 V 3 AC 50 Hz
TN3000	D-.xx.S.xx.G.xx	5.500	39.000	5,5/7,5	ON REQUEST	230 V 1N AC 50 Hz	400 V 3 AC 50 Hz

TPBY^{TYPE} TPBY90 ... TPBY3000

with viscosity up to 4000 cSt at 50°C (530°E at 50°C) - PNEUMATIC ATOMIZATION

HEAVY OIL

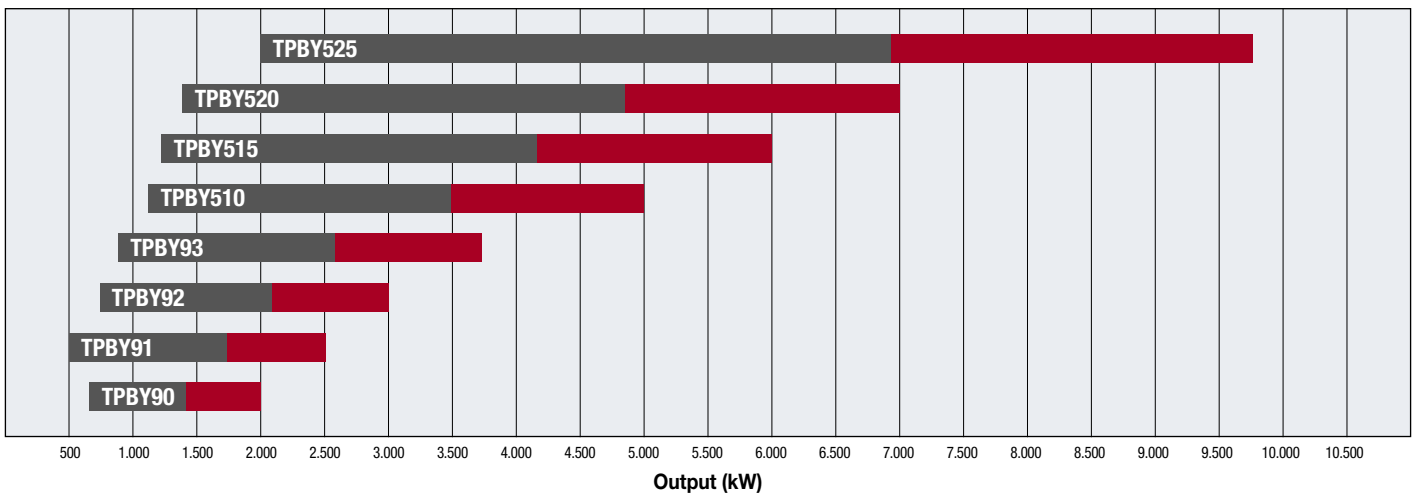
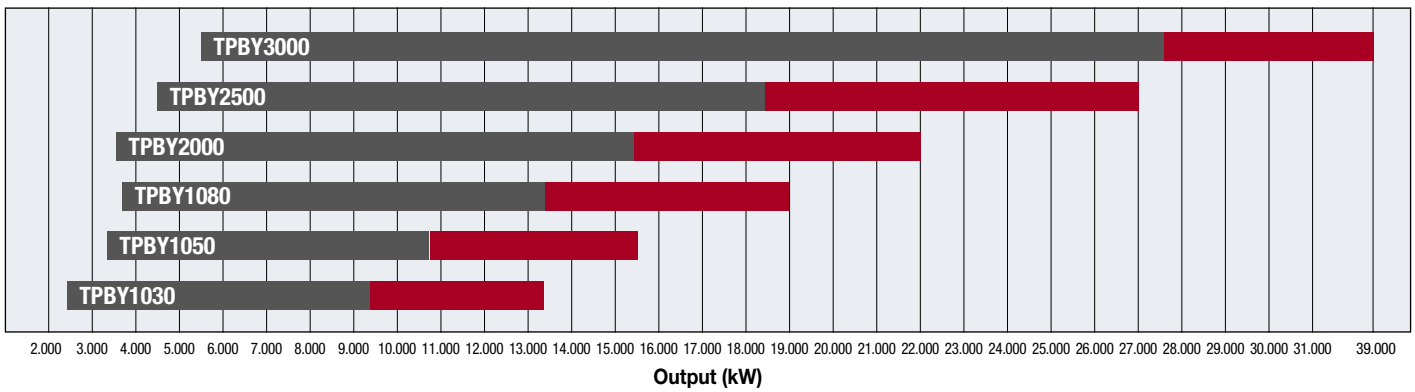

Type	Min. modulation output kW	Min. application output kW	Max output kW
TPBY90	670	1.400	2.000
TPBY91	500	1.750	2.500
TPBY92	700	2.100	3.000
TPBY93	900	2.590	3.700
TPBY510	1.100	3.500	5.000
TPBY515	1.200	4.200	6.000
TPBY520	1.400	4.900	7.000
TPBY525	2.000	6.825	9.750
TPBY1030	2.550	9.310	13.300
TPBY1050	3.100	10.850	15.500
TPBY1080	3.800	13.300	19.000
TPBY2000	3.600	15.400	22.000
TPBY2500	4.500	18.400	27.000
TPBY3000	5.500	27.300	39.000

TECHNICAL DETAILS

Type	Model	Power kW		Pump motor	Resistor	Auxiliary electrical power supply	Motor electrical power supply
		min.	max.	kW	kW		
TPBY90	H-.xx.S.xx.G.xx	670	2.000	0,75	8	230 V 1N AC 50 Hz	400 V 3 AC 50 Hz
TPBY91	H-.xx.S.xx.G.xx	500	2.500	0,75	8	230 V 1N AC 50 Hz	400 V 3 AC 50 Hz
TPBY92	H-.xx.S.xx.G.xx	700	3.000	0,75	12	230 V 1N AC 50 Hz	400 V 3 AC 50 Hz
TPBY93	H-.xx.S.xx.G.xx	900	3.700	0,75	12	230 V 1N AC 50 Hz	400 V 3 AC 50 Hz
TPBY510	H-.xx.S.xx.G.xx	1.100	5.000	0,75	18	230 V 1N AC 50 Hz	400 V 3 AC 50 Hz
TPBY515	H-.xx.S.xx.G.xx	1.200	6.000	0,75	18	230 V 1N AC 50 Hz	400 V 3 AC 50 Hz
TPBY520	H-.xx.S.xx.G.xx	1.400	7.000	0,75	24	230 V 1N AC 50 Hz	400 V 3 AC 50 Hz
TPBY525	H-.xx.S.xx.G.xx	2.000	9.750	1,1	24	230 V 1N AC 50 Hz	400 V 3 AC 50 Hz
TPBY1030	H-.xx.S.xx.G.xx	2.550	13.300	1,1	24 + 24	230 V 1N AC 50 Hz	400 V 3 AC 50 Hz
TPBY1050	H-.xx.S.xx.G.xx	3.100	15.500	1,1	24 + 24	230 V 1N AC 50 Hz	400 V 3 AC 50 Hz
TPBY1080	H-.xx.S.xx.G.xx	3.800	19.000	1,5	24 + 24	230 V 1N AC 50 Hz	400 V 3 AC 50 Hz
TPBY2000	H-.xx.S.xx.G.xx	3.600	22.000	5,5	ON REQUEST	230 V 1N AC 50 Hz	400 V 3 AC 50 Hz
TPBY2500	H-.xx.S.xx.G.xx	4.500	27.000	5,5	ON REQUEST	230 V 1N AC 50 Hz	400 V 3 AC 50 Hz
TPBY3000	H-.xx.S.xx.G.xx	5.500	39.000	5,5	ON REQUEST	230 V 1N AC 50 Hz	400 V 3 AC 50 Hz

TPBY... VS TYPE TPBY93 ... TPBY1080

with viscosity up to 4000 cSt at 50°C (530°E at 50°C) - PNEUMATIC ATOMIZATION

HEAVY OIL

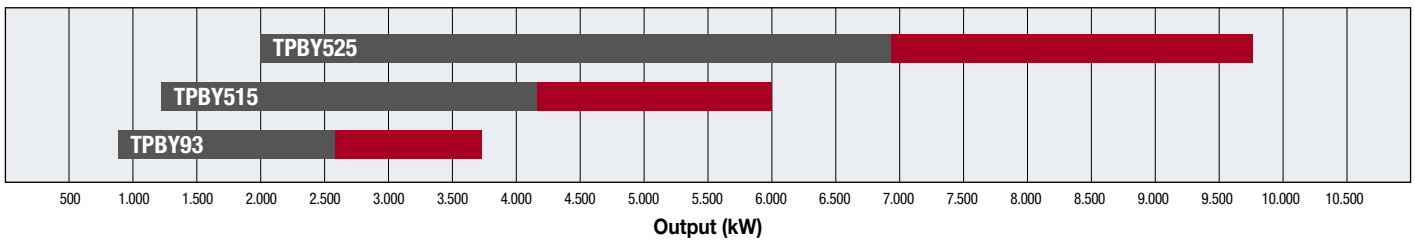
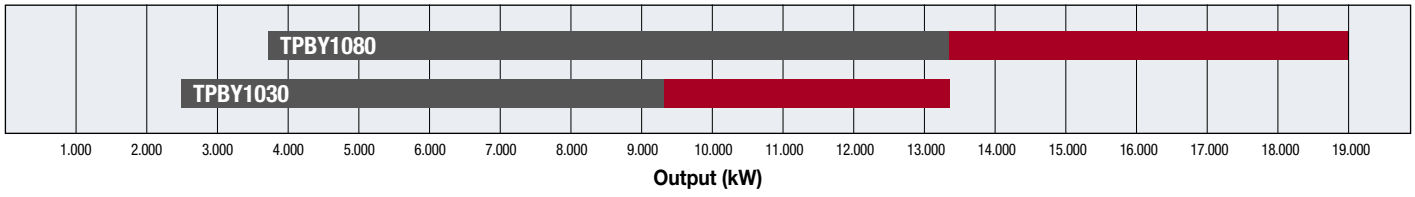
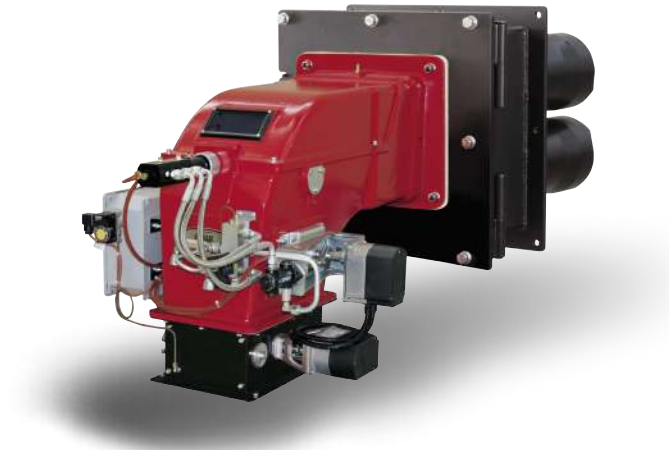

Type	Min. modulation output kW	Min. application output kW	Max output kW
TPBY93	900	2.590	3.700
TPBY515	1.200	4.200	6.000
TPBY525	2.000	6.825	9.750
TPBY1030	2.550	9.310	13.300
TPBY1080	3.800	13.300	19.000

TECHNICAL DETAILS

Type	Model	Power kW		Pump motor	Resistor	Auxiliary electrical power supply	Motor electrical power supply
		min.	max.	kW	kW		
TPBY93	H-.xx.S.xx.G.xx	900	3.700	0,75	12	230 V 1N AC 50 Hz	400 V 3 AC 50 Hz
TPBY515	H-.xx.S.xx.G.xx	1.200	6.000	0,75	18	230 V 1N AC 50 Hz	400 V 3 AC 50 Hz
TPBY525	H-.xx.S.xx.G.xx	2.000	9.750	0,75	24	230 V 1N AC 50 Hz	400 V 3 AC 50 Hz
TPBY1030	H-.xx.S.xx.G.xx	2.550	13.300	1,1	18 + 18	230 V 1N AC 50 Hz	400 V 3 AC 50 Hz
TPBY1080	H-.xx.S.xx.G.xx	3.800	19.000	2,2	24 + 24	230 V 1N AC 50 Hz	400 V 3 AC 50 Hz

DUAL FUEL BURNERS NATURAL GAS/LIGHT OIL LOW NO_x

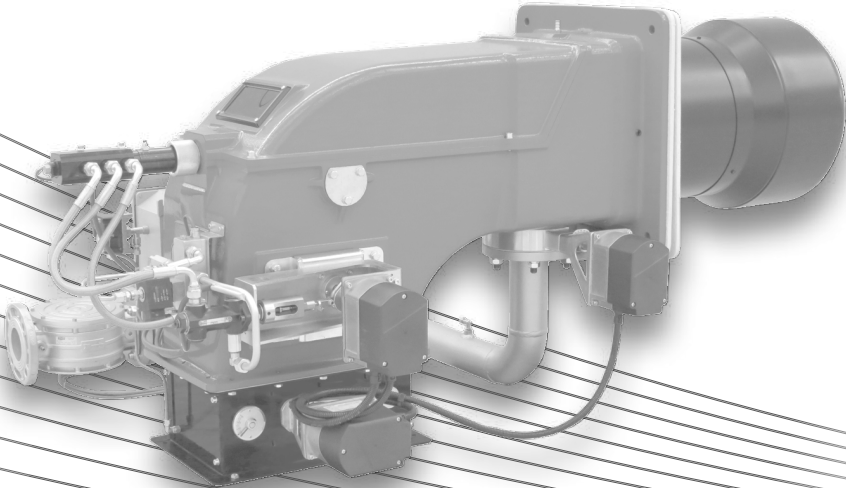

OPTIONS HEAVY OIL BURNERS

HEAVY OIL FILTERS



Model	Code
Filter 1" 0,3 micron big up to burner size 90-500	2090207
Filter 1½" 0,3 for PBY90-500	2090236
Filter 51000/05 F (flanged DN50) (1000-2000 burners series)*	2090237
Magnetic filter 1½" max 500 kg/h	2090245

*With 300 W heater

VACUUM GAUGE



Model	Code
Glycerine vacuum gauge -1 ÷ 0 bar (¼" connection)	2520008

MANOMETER



Model	Code
Glycerine gauge 0 ÷ 6 bar (¼" connection)	2520035
Glycerine gauge 0 ÷ 10 bar (¼" connection)	2520036
Glycerine gauge 0 ÷ 16 bar (¼" connection)	2520033
Glycerine gauge 0 ÷ 25 bar (¼" connection)	2520034
Glycerine gauge 0 ÷ 40 bar (¼" connection)	2520019

SUPPORT FOR PRESSURE GAUGE manometer / vacuum gauge



Model	Code
Isolating valve (¼" connection)	2520005

DEGASSING BOTTLE



Model	Diameter	Code
Threaded	1"½	3040117
Flanged	DN40	3040121

BELT HEATER CABLE FOR PIPES



Model	Type	Code
Power 64 Watt/meter	each meter	ON REQUEST

MANUAL CUT OFF VALVE (BALL VALVE)



Model	Code
1"	2810024
1"½	2810025
2"	2810031
2"½	ON REQUEST

OPTIONS HEAVY OIL BURNERS

OIL PRE-HEATING TANK (STEAM/DIATHERMIC OIL)

Type	Capacity kg/h	Tank volume liters	Electrical heaters kW	Max temperature °C	Max pressure bar
HTS5	500	500	12	80÷100	5
HTS10	1.000	1.500	18	80÷100	5
HTS20	2.000	2.000	24	80÷100	5
HTS30	3.000	3.000	24	80÷100	5
HTS40	4.000	4.000	24	80÷100	5

Vertical cylindrical tanks, provided with electrical resistance and spiral heat exchanger.

Upon order please specify if the spiral must be provided for diathermic oil or steam.

Electrical panel mounted aboard.

Packaging included.

The oil flow rate is indicative: it can vary according to the type of fuel and to the thermal step required.

OIL PRE-HEATING TANK (ONLY ELECTRICAL RESISTANCES/HOT WATER)

Type	Capacity kg/h	Tank volume liters	Electrical heaters kW	Max temperature °C	Max pressure bar
HT2	200	200	8	80÷100	5
HT5	500	500	12	80÷100	5
HT10	1.000	1.500	18	80÷100	5
HT20	2.000	2.000	24	80÷100	5
HT30	3.000	3.000	24	80÷100	5
HT40	4.000	4.000	24	80÷100	5

Vertical cylindrical tanks, provided with electrical resistance and spiral heat exchanger (optional).

Upon order please specify electrical resistances only or hot water coil.

Electrical panel mounted aboard.

Packaging included.

The oil flow rate is indicative: it can vary according to the type of fuel and to the thermal step required.



CRUDE AND HEAVY OIL PRESSURE REGULATOR GROUPS

Type	Capacity kg/h	Diameter
GRP-D2	500	DN50
GRP-D4	800	DN50
GRP-D7	1.300	DN50
GRP-D10	2.000	DN50
GRP-D13	2.500	DN50
GRP-D20	4.000	DN50

Pressure regulator group supplied pre-assembled (no frame).
Packaging included.
For greater flow rates, quotations upon request.

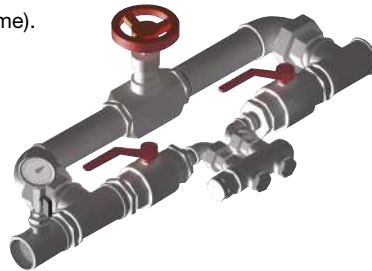

LOW PRESSURE OIL HANDLING UNIT (RING) - HEAVY/RAW OIL - 2 PUMPS IN PARALLEL (ONE AS BACK-UP)

Type	Capacity kg/h	Power kW	Diameter	Dimensions a x b x h (mm)
GS-D2	500	2.700	DN50	1.300 x 900 x 800
GS-D4	800	4.500	DN50	1.500 x 900 x 800
GS-D7	1.300	6.900	DN50	1.600 x 1.200 x 800
GS-D10	2.000	10.800	DN50	1.600 x 1.200 x 800
GS-D13	2.500	13.900	DN50	1.800 x 1.500 x 800
GS-D20	4.000	20.000	DN50	1.800 x 1.500 x 800

LOW PRESSURE OIL HANDLING UNIT (RING) - HEAVY/RAW OIL - SINGLE PUMP

Type	Capacity kg/h	Power kW	Diameter	Dimensions a x b x h (mm)
GS-D2s	500	2.700	DN50	1.300 x 600 x 800
GS-D4s	800	4.500	DN50	1.500 x 600 x 800
GS-D7s	1.300	6.900	DN50	1.600 x 800 x 800
GS-D10s	2.000	10.800	DN50	1.600 x 800 x 800

The output is referred to the burners which can be supplied by the low pressure ring.

The flow rate is referred to the heavy oil flow rate pumped into the ring.

Dimensions are indicative.

Dimensions do not include the electrical panel, the panel can be installed on the oil ring, or wall-hung (dimensions 400 x 250 x 600 h mm).

For greater flow rates, quotations upon request.

In order to pick up the correct oil ring to your application, refer to the output and choose the larger ring size. Match the ring to the regulation group of the same size. To finish the job remember to choose the degassing tanks (the use of degassing tanks is mandatory when 2 or more burners are supplied by the same ring, only recommended in all other cases).

